



Mission Rubber Company LLC

1660 Leeson Lane
 Corona, CA 92879
 (800) 854-9991 • Fax (800) 637-4601
 missionrubber.com



**For Heavy Duty
 Installations Requiring
 More Than a Standard
 No Hub Coupling**

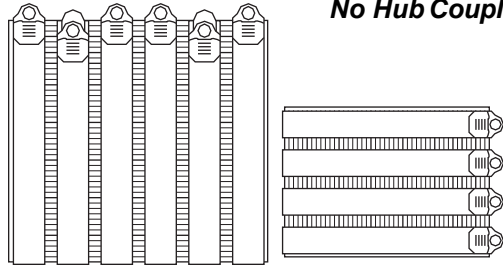

SIZES 1½" THROUGH 4" - 4 BANDS
 SIZES 5" THROUGH 15" - 6 BANDS

CLAMP DETAILS

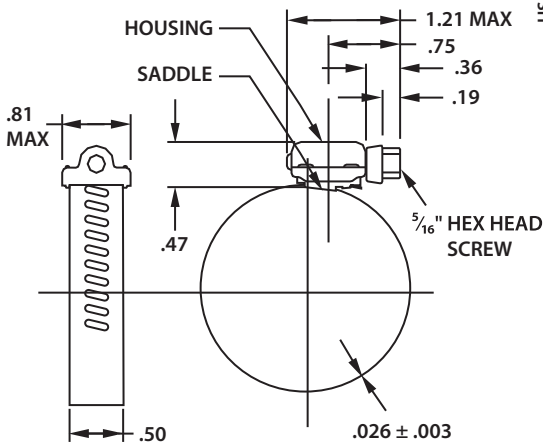

MEETS:
 ASTM C 1540
 ASTM C 564
 ASTM A240/A240M
 CSA B602
 IAPMO 7816



TYPICAL BAND TENSION VS. HW TORQUE
 (AISI 305 SCREWS)

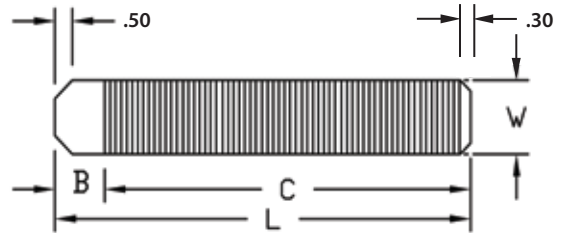
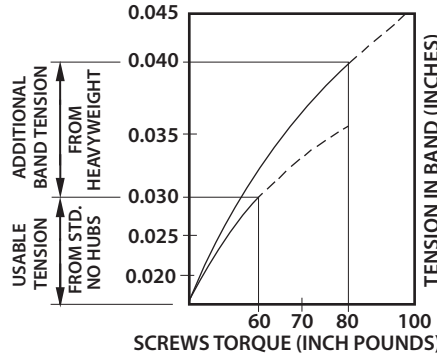

CORRUGATED SHIELD DETAILS

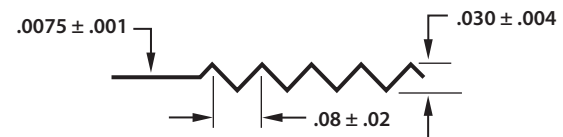

SEALING GASKET DETAILS

SIZES 1½" - 4"
 6 SEALING
 RINGS/SIDE

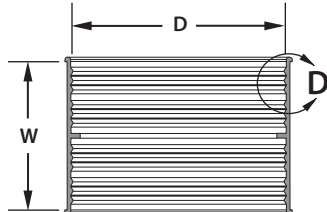

SIZES 5" - 10"
 9 SEALING
 RINGS/SIDE

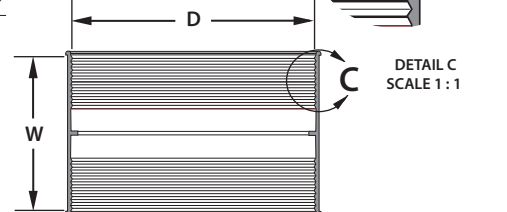

MISSION REFERENCE	CORRUGATED SHIELD DIMENSIONS			
	B	C	L	W
1½" - C150 HW	0	7.813	7.813	3
2" - C200 HW	0	9.313	9.313	3
2" x 1½" - C215 HW	0	9.313	9.313	3
3" - C300 HW	0	12.563	12.563	3
3" x 2" - C320 HW	0	12.563	12.563	3
4" - C400 HW	0.875	15.063	15.938	3
4" x 3" - C430 HW	0.875	15.063	15.938	3
5" - C500 HW	2.750	17.500	20.250	4
6" - C600 HW	2.750	19.875	22.625	4
8" - C800 HW	2.750	26.250	29.000	4
10" - C1000 HW	2.750	33.813	36.563	4
12" - C1200 HW	4.000	39.000	43.000	5.5
15" - C1500 HW	4.000	49.875	53.875	5.5

SEALING GASKET DIMENSIONS	
D	W
1½"	3
2"	3
2" x 1½"	3
3"	3
3" x 2"	3
4"	3
4" x 3"	3
5"	4
6"	4
8"	4
10"	4
12"	5.5
15"	5.5

TEST	GASKET PHYSICAL TESTS (ASTM C 564)	ASTM C 564
Tensile Strength	1500 PSI minimum	D412
Elongation	250% minimum	D412
Durometer (Shore A)	70 ± 5 @ 76°F ± 5°F	D2240
Accelerated Aging	15% maximum tensile and 20% maximum elongation deterioration. 10 points maximum increase in hardness. All determinations after oven aging for 96 hours at 158°F.	D573
Compression Set	25% maximum after 22 hours at 158°F	D395
Oil Immersion	80% maximum volume change after immersion in ASTM oil #3 for 70 hours at 212°F	D471
Ozone Cracking	No visible cracking at 2X magnification of the gasket after 100 hours exposure in 1.0 PPHM ozone concentration at 104°F. Testing and inspection to be on gasket which is loop-mounted to give approximately 20% elongation of outer surface.	
Tear Resistance	Die C 150 lbs. minimum per inch of thickness	D624
Water Absorption	20% maximum by weight after 7 days at 158°F	D471

Mission's HeavyWeight Coupling is designed to connect cast iron hubless soil pipe and fittings in sanitary and drain waste and vent (DWV) applications. Couplings consist of multiple heavy duty 304 series stainless steel worm drive clamps attached to a heavy duty corrugated 304 series stainless steel shield, over a molded one-piece elastomeric sealing gasket. Couplings are available in sizes 1½" to 15": 1½" to 4" utilize four (4) clamps; 5" to 15" utilize six (6) clamps.
 Leak-Proof Seal - Stainless steel clamps are 8% thicker than those of a standard no hub coupling, providing a positive seal when properly tightened to 80 in/lbs. of torque. Axially slotted clamps enable bands to tighten independently to accommodate variances in the outside diameters of the pipe and fittings to be joined, ensuring a water-tight, leak-proof and root-proof seal.
 Corrosion Resistant - 304 series stainless steel components provide highly effective corrosion resistance in a variety of environments.

Extended Width - Greater surface load bearing contact of 304 stainless steel shield accommodates additional sealing clamps and provides for greater load bearing control between the coupling and surface of the pipe and fitting.
 Joint Movement Restraint - Additional sealing rings are incorporated into the circumferentially continuous sealing gasket and meet the requirements of ASTM C 564. The internal profile of the elastomeric gasket ensures a uniform seal throughout the entire coupling, increasing performance in all cast iron DWV systems.
 Pre-Set Calibration - All HeavyWeight Couplings are designed to be installed with a pre-set torque wrench calibrated to 80 in/lbs. maximum to accommodate the 305 stainless steel 5/16" hex head/shoulder screw.